



RS17 RINGSAW INSTRUCTIONS

P/N 2017101 AND 2017104

REIMANN & GEORGER CORPORATION
CONSTRUCTION PRODUCTS

P/N 6122067

02/13/19

TABLE OF CONTENTS

CHAPTER	TITLE	PAGE
1	SAFETY	1
1.1	Introduction	1
1.2	Safety Definitions	1
1.3	Power Source and Saw Safety Labels	1
1.4	RS17 Saw Safety Rules	1
2	SPECIFICATIONS	3
2.1	Introduction	3
2.2	Technical Data	3
2.3	Blade Performance Requirements	4
2.4	Hydraulic Power Source Requirements	4
2.5	Recommended Hydraulic Oil	4
2.6	Nameplate and Serial Number Tag	4
3	OPERATION	6
3.1	Component Pre-Start Checks	6
3.1.1	Hydraulic System	6
3.1.2	Drive Wheel and Blade	6
3.2	Starting the System	7
3.3	Cutting Procedure	7
3.4	Shutdown and Storage	8
3.5	Cold Weather Operation	9
3.6	Water Supply	9
4	INSPECTION AND MAINTENANCE	10
4.1	General Maintenance Rules	10
4.2	Daily Inspection and Maintenance	10
4.3	Blade and Drive Wheel Removal and Installation	10
4.3.1	Blade and Drive Wheel Removal	10
4.3.2	Blade and Drive Wheel Installation	11
4.4	Drive Wheel Removal and Installation Diagram	12
5	TROUBLESHOOTING	13
5.1	Locating the Problem Area	14
5.2	Troubleshooting the Saw	15
6	PARTS LIST	16

LIST OF FIGURES

FIGURE	DESCRIPTION	PAGE
2-1	Typical RS17 Product Nameplate	5
4-1	Drive Wheel Removal and Installation Diagram	12
6-1	RS17 RingSaw Overall Dimensions	17
6-2	How Does RGC RingSaw Work	18
6-3	Roller Assemblies in Roller Frame Diagram	19
6-4	Exploded Assembly Part 1	20
6-5	Exploded Assembly Part 2	21
6-6	Exploded Assembly Part 3	22

1 SAFETY

1.1 INTRODUCTION

Your RS17 Ring Saw has been engineered to provide sawing performance, long term economics and safety advantages that no other type can match. However, even a well-designed and well-built saw can malfunction or become hazardous in the hands of an inexperienced and/or untrained user. Therefore, read this manual and related equipment manuals thoroughly before operating your saw to provide maximum safety for all operating personnel, and to get the maximum benefit from your equipment.

1.2 SAFETY DEFINITIONS

A safety message alerts you to potential hazards which could injure you or others or cause property damage. The safety messages or signal words for product safety signs are **DANGER**, **WARNING**, and **CAUTION**. Each safety message is preceded by a safety alert symbol and is defined as follows:

DANGER: Indicates an imminently hazardous situation which, if not avoided, **will** cause death or serious injury. This safety message is limited to the most extreme situations.

WARNING: Indicates a potentially hazardous situation which, if not avoided, **could** result in death or serious injury.

CAUTION: Indicates a potentially hazardous situation which, if not avoided, **may** result in minor or moderate injury. It may also be used to alert against unsafe practices that may result in property-damage-only accidents.

1.3 POWER SOURCE AND SAW SAFETY LABELS

These labels warn you of potential hazards which could cause injury. Read them carefully. If a label comes off or becomes illegible, contact the dealer for a replacement.

1.4 RS17 RING SAW SAFETY RULES

1. Only trained personnel shall operate the saw or perform repairs. A trained person is one who has read and thoroughly understands this instruction manual and related equipment manuals and, through training and experience, has shown knowledge regarding the safe operational procedures.
2. Sawing area must be kept clear of unauthorized personnel at all times. Place barricades or secure the area with signs and a roped boundary to prevent personnel injury.
3. Never use the saw in an explosive atmosphere and/or near combustible material that could be ignited by a spark.
4. Do not use a saw that shows any signs of damage. Do not use the saw if the blade does not stop rotating when the power-activating trigger lever is released.
5. The guard provides protection against contact with moving parts, ejected debris, and during wet cutting operations, thrown water and concrete slurry. Adjust the blade guard for the cut being made. Never run the saw without the blade guard in place.
6. Never allow anyone to stand in front of, or in line with, the blade forward of the guard.
7. Always use blades that meet applicable safety code specifications. Read and comply with blade manufacturer's instructions and safety precautions provided with the blade. Destroy any blade with cracks, chips, gouges, or loose or missing tips.
8. **Always** use safety footwear, safety goggles or face shields, and hearing and head protection devices. Safety shoes **MUST** provide good footing to prevent slipping or falling down. Gloves protect the hands from chips and should be worn. During dry cutting operations, provide also adequate ventilation or approved NIOSH or MSHA respirators in closed areas to avoid breathing dust. During wet cutting operations, use also a snug fitting wet suit.
9. Do not use the saw when you are tired or fatigued.

10. Never operate the saw under the influence of drugs, alcohol, or medication.
11. Always carry the saw in its de-energized state.
12. Keep the saw handles dry, clean, and free of oil or fuel.
13. This saw is not insulated. Do not start cutting without first de-energizing electrical wiring near the cutting site or imbedded in any concrete.
14. Prior to cutting, plan your cuts to prevent pinching of the blade or personnel injury from falling material.
15. Always hold the saw with both hands during operation. Use a firm grip on the handles.
16. Never exceed the flow and pressure rating of the saw which is 12 gpm at 2500 psi.
17. Do not exceed either the blade maximum operating speed of 3240 rpm or the blade manufacturer's rated speed.
18. Do NOT attempt to adjust the saw during operation.
19. Keep clothing and all parts of the body away from moving parts of this saw when connected to a power source or being used.
20. Any slurry formed during wet cutting operations is very slick. Remove while still wet to prevent yourself or others from slipping while cutting. Slurry that has been allowed to dry is very difficult to remove.
21. Always shut off the hydraulic power and cooling water sources before disconnecting the hoses or servicing the saw. Never remove fittings or components when hydraulic fluid is hot.
22. Always shut off the hydraulic and cooling water sources when not using the equipment.

2 SPECIFICATIONS

2.1 INTRODUCTION

Your RS17 RingSaw is a hydraulic direct drive saw that is a rugged versatile tool that cuts cleanly, fast, precisely, and straight through concrete, steel, stone, wood, composition material, or hard fiber when equipped with the appropriate abrasive, diamond, or carbide tipped blade. The slim line design of the saw allows cuts to be made within inches of a wall or an obstruction. The saw is equipped with an adjustable 180° blade guard, water hose connection port for wet cutting and 12-inch long hose whips. An arbor wrench is provided for removing and installing blades. As with most hydraulic tools, the hydraulic system requirements detailed in the following sections must be met but not exceeded to support tool performance and longevity of equipment.

The following features are provided:

- 12-inch hose whips
- Blade drive wheel
- Trigger actuated water supply
- Trigger lockout
- Ergonomic handle design

2.2 TECHNICAL DATA

The following specifications apply to the RS17 RingSaw.

	ENGLISH	METRIC
Tool Physicals		
Weight without hoses & blade	30 lbs.	(13.7 kg)
Length (w/o blade)	28 in.	(711 mm)
Length (w/ Blade)	30.1 in.	(765 mm)
Width	11.5 in.	(292 mm)
Maximum Blade Diameter	17 in.	(432 mm)
Drive Wheel Diameter	2.2 in.	(56 mm)
Hydraulic Requirements		
Type of System		Open-Center
Flow Rate	12 gpm	(45 lpm)
Max Pressure Range	2000-2500 psi	(138-172 bar)
Max Pressure Relief Setting	2500 psi @ 12 gpm	(172 bar @ 45 lpm)
Filtration		10 microns (nominal)
Back Pressure (Max)	78 psi	(5.5 bar)
Hose Length (Max)	150 ft.	(45 m)
Couplings		1/2" HTMA flush face
Water Requirements for Wet Cutting	2.5 psi @ 50 gpm	(1.1 lpm @ 3.4 bar)
Operation		
Power	17.5 Hp	(13 kw)
Torque	218 in.-lbs.	(25 Nm)
Speed @ 12 gpm		2340 rpm
Cutting Depth	12.5 in.	(317 mm)

2.3 BLADE PERFORMANCE REQUIREMENTS

Any blade from your supplier must meet the following design criteria. **Using blades on this saw that don't meet these requirements can cause equipment damage and/or personal injury.**

1. Use blades that meet applicable industrial safety code specifications.
2. Use blades that are approved by the blade manufacturer for the material to be cut.
3. Do not exceed either the blade maximum operating speed of 3240 rpm or the blade manufacturer's rated speed. Blades must be speed tested to ANSI B7.1 safety code specifications.

2.4 HYDRAULIC POWER SOURCE REQUIREMENTS

The hydraulic power source must meet the following design criteria.

1. The flow must not exceed 12 gpm and the pressure relief valve must not exceed 2500 psi @ 12 gpm. **Failure to comply could cause excessive blade rpm and/or overpressurizing the system, resulting in equipment damage and/or personal injury.**
2. The hydraulic power source must conform to the technical specifications of Section 2.2.
3. Hoses and fittings must comply with S.A.E. Standard J1273.

2.5 RECOMMENDED HYDRAULIC OIL

Viscosity	140-225 SUS @ 100°F	(28-45 cSt @ 38°C)
	40 min. SUS @ 210°F	(8 min. cSt @ 99°C)
Flash Point	340°F min.	(170°C min.)
Pour Point	-30°F min.	(-34°C min.)

Many types of compatible hydraulic oil are available through your local dealer/distributor. As an original equipment manufacturer, a Grade ISO VG 32 hydraulic turbine oil is used.

Hydraulic oil types are too numerous to list in this manual. If you have any question concerning the type of oil suitable for HydraSaw operation, please consult your local supplier for details.

2.6 NAMEPLATE AND SERIAL NUMBER TAG

It is important to identify the saw completely and accurately whenever ordering spare parts or requesting assistance in service. The saw has a product nameplate that states the model and serial numbers. The saw label should appear as the sample nameplate shown in Figure 2-1. Record the model and serial numbers for future reference.

PART NO. _____
SER. NO. _____

Figure 2-1.
Typical RS17 Product Nameplate

MODEL _____

SERIAL NUMBER _____

3 OPERATION

Follow all the safety procedures in Chapter 1 of this manual and in the manual supplied with your hydraulic power unit. **Failure to do this can cause equipment damage and/or personal injury.** Make sure you are wearing all your safety equipment including approved NIOSH or MSHA respirators during dry cutting or a wet suit during wet cutting.

3.1 COMPONENT PRE-START CHECKS

The following components must be checked before you can use the saw safely. Running the saw with an undetected defect in either of these components will quickly cause equipment damage.

- Hydraulic system
- Drive Wheel and Blade

3.1.1 Hydraulic System

1. Before making any hydraulic connections, inspect all hoses for leaks and risks of rupture as follows:
 - a. Inspect each hose for breaks, cracks, worn spots, bulges, chemical attack, kinks or any other damage. Never stop any detected leak with your hand or fingers. Do not put your face close to suspected leaks. Hold a piece of cardboard close to suspected leaks and then inspect the cardboard for signs of hydraulic oil.
 - b. Replace a damaged hose immediately. Never repair the hose.

2. CONNECTING HYDRAULIC HOSES

- Wipe all hose couplers with a clean lint free cloth before making connections. Do not connect pressure to the return port.
- Connect the return (tank) line from the saw return port to the hydraulic power source return port. Then connect the pressure line from the saw pressure port to the hydraulic power source pressure port.
- Make sure the hydraulic hoses are connected properly and fully seated to ensure that the flow is in the proper direction.
- Pressure relief valve must not exceed 2500 psi @ 12 gpm. The pressure relief valve must be located in the supply circuit between the power supply and tool to limit excessive hydraulic pressure to the tool.
- **Note: If uncoupled hoses are left in the sun, pressure increase inside the hoses might make them difficult to connect. Whenever possible, connect the free ends of the hoses together when not in use.**



WARNING:

COVER THE FITTING END WITH A RAG TO REDUCE THE RISK OF BEING SPRAYED WITH HYDRAULIC FLUID. ESCAPING FLUID UNDER PRESSURE CAN PENETRATE THE SKIN AND CAUSE SERIOUS PERSONAL INJURY. IF INJURY OCCURS, GET IMMEDIATE MEDICAL ATTENTION.

3.1.2 Drive Wheel and Blade

1. Inspect the drive wheel and mounting flange for gouges, hairline cracks, and wear. Replace these immediately if any of these conditions are present as described in Chapter 4.
2. Be sure the drive wheel & mounting flange are clean and straight so blade will run true in “V” slot.
3. Be sure the drive wheel & mounting flange are tightened securely.
4. Always use the blade recommended by the blade manufacturer for your application.

5. Inspect the blade for cracks, chips, gouges, or loose or missing tips. Destroy the blade if any of these conditions are present.
6. Ensure a blade is installed to blade manufacturer's specified direction of rotation. Saw rotation is clockwise as viewed from the guide roller side of the saw.
7. Check that Blade can be turned by hand, before saw is connected to hydraulics.

3.2 STARTING THE SYSTEM

1. This saw is not insulated. Do not start cutting without first checking for live electrical wiring near the cutting site, or imbedded in the cutting medium. If power lines are unavoidable, consult power company before starting operation.
2. The following precautions must be observed when lifting the saw:
 - a. Be sure of your footing.
 - b. Keep hands off trigger to avoid accidental operation.
 - c. Bend your knees and lift with your legs.
 - d. Hold saw close to your body when lifting.
3. Ensure the power supply is turned off.



WARNING:

THE GUARD PROVIDES PROTECTION AGAINST CONTACT WITH MOVING PARTS, EJECTED DEBRIS, AND DURING WET CUTTING OPERATIONS, THROWN WATER AND CONCRETE SLURRY. NEVER RUN THE SAW WITHOUT THE BLADE GUARD IN PLACE.

4. Always check the gpm and psi rating of both the saw and the power drive before using to prevent equipment damage. Do not exceed the maximum hydraulic flow rate and pressure of 12 gpm (45 lpm) and 2500 psi (172 bar). Overspeeding the blade can cause equipment damage and possible personal injury.
5. Check that the pressure and return hoses are connected properly to the saw and power source ports as described in Section 3.1.1.
6. Before starting your power supply, read and fully understand the operating manual provided.
7. Use caution when handling fuel for a gasoline engine driven hydraulic power source unit. Move the hydraulic power source at least 10 feet from the fueling point before starting the engine. Make sure the gas caps on the hydraulic power source and fuel can are properly tightened.

3.3 CUTTING PROCEDURE

1. Connect water supply.
2. Set power source to "ON".
3. Open water supply.
4. Provide rigid support and "hold down" of piece being cut—both sides of the cut, if practical.
5. Grasp the auxiliary handle with your left hand. Use the appropriate part of the handle for making vertical or horizontal cuts.

6. Grasp the trigger with your right hand.
7. Position the saw in the appropriate place to make the desired cut.
8. Depress (squeeze) the trigger to start the saw. Never exceed either the blade maximum operating speed of 3240 rpm or the blade manufacturer's rated speed.
9. Feed the rotating blade into the work surface using a straight, steady, constant pressure. Do NOT "bump," jam or force the blade into the work surface, or twist the blade in the cut. This can cause equipment damage.
10. Start by holding the blade towards the material. When gradually a groove is cut, press the blade towards the material and cut in lines of 2-3 inches until you have cut through the material. This is the quickest way of cutting instead of cutting through in one attempt.
11. It is important to keep the water supply steady and sufficient as it cools the blade, removes the slurry and guarantees you the best result with as little wear on the blade and rollers as possible.

Stop

- Remove the blade from the material and let go of the trigger lever
- Set the power source on "OFF"
- Disconnect water supply



Note: For easier cleaning let the blade spin in the air with full water running for 30 seconds. It will help removing slurry from blade and rollers. RGC recommends cleaning each roller for slurry after usage for longer lifetime and better adjustment of blade. See separate instruction.



WARNING:

ALWAYS START AND FINISH A SAW CUT WITH THE SAME WIDTH OF BLADE. IF BLADE TYPE OR WIDTH IS CHANGED, START A NEW SAW CUT. FAILURE TO DO THIS CAN CAUSE EQUIPMENT DAMAGE AND/OR PERSONAL INJURY.

3.4 SHUTDOWN AND STORAGE

1. To stop the saw, release the trigger.
2. AFTER the blade has stopped rotating, lay the saw on a flat surface.
3. Stop the hydraulic power source following the procedure in the respective instruction manual.
4. Shut off water supply.



CAUTION:

ALWAYS SHUT OFF THE COOLING WATER WHEN THE TOOL IS NOT IN USE. LEAVING THE WATER RUNNING UNATTENDED CAN CAUSE EQUIPMENT OR PROPERTY DAMAGE.

5. Clean concrete slurry and debris off saw. Once concrete slurry is dry, it is very hard to remove and may hamper the operation of moving parts.
6. Disconnect the hoses from the saw.



WARNING:

NEVER DISCONNECT ANY HYDRAULICALLY OPERATED PART OF THE SAW OR REMOVE HYDRAULIC COMPONENTS, LINES, OR FITTINGS WHILE THE POWER SOURCE IS RUNNING OR WHENEVER THE HYDRAULIC FLUID IS HOT.

LIQUID UNDER HIGH PRESSURE CAN PIERCE THE SKIN, CAUSING SERIOUS INJURY OR DEATH. HOT LIQUID CAN CAUSE SERIOUS PERSONAL BURNS. IF AN INJURY OCCURS, GET IMMEDIATE MEDICAL ATTENTION.

7. Secure the saw and hydraulic power source to prevent unauthorized use.
8. Store the saw in a clean, dry area away from exposure to high heat and humidity, water, other liquids, or freezing temperatures. Avoid temperatures low enough to cause condensation on the blade when moving it from storage to a higher temperature. Always handle and store blades carefully.
9. Do not stack material on top of the saw that may cause the blade to bend or deform.

3.5 Cold Weather Operation

If the ring saw is to be used during cold weather, preheat the hydraulic fluid at low power source speed. When using the normally recommended fluids, fluid should be at or above freezing level 32°F/0° C before use. Damage to the hydraulic system or hydraulic motor seals can result from use with fluids that is too viscous or thick.

Note: Remember to empty the saw of water after cutting in freezing conditions to avoid damage.

- Disconnect water hose.
- Orientate saw in a vertical position with the right Handle Valve (12) at the high point. This will allow water in the Roller Frame (16) to drain out of the (4) roller areas. Duration 30 seconds.
- Reverse orientation, so that the right handle is at the lowest point in the vertical position. This will allow water to Drain out of the Handle Valve (12). Duration 10 seconds.

3.6 Water Supply

Only use with water. Make sure water supply is sufficient. Abrasive material and too little water when cutting increases wear on the drive wheel and the inner edge of the blade and may cause the blade to slip.

Note: The recommended minimum water supply is 2.5 [gpm@ 50 psi](#).

4 INSPECTION AND MAINTENANCE

4.1 GENERAL MAINTENANCE RULES

1. Proper maintenance of the saw and related equipment requires timely adhering to all the guidelines given in this chapter. Proper maintenance is required to maintain the system in good condition and free of defects.
2. Review and follow all the safety rules given in Chapter 1 before attempting any maintenance.
3. Before starting any maintenance always wear appropriate personal safety equipment.
4. Only authorized personnel should be allowed in the maintenance area. Authorized personnel are the trained people as defined below and their supervision.
5. Repairs must be made only by trained personnel. A trained person is one who has read and thoroughly understands this instruction manual and related equipment manuals and, through training and experience, has shown knowledge regarding the safe operational procedures.
6. Disconnect the cooling water and power supplies before starting.



WARNING:

FAILURE TO DISCONNECT THE POWER SUPPLY BEFORE STARTING CAN CAUSE EQUIPMENT DAMAGE AND/OR PERSONAL INJURY.

7. Hydraulic fluid can become contaminated after extended periods of use which can cause restrictions in the system. Check to see that the fluid is clean and change at recommended intervals to extend saw's life. Refer to the respective manual for maintenance information on the hydraulic power source.

4.2 DAILY INSPECTION AND MAINTENANCE

1. Inspect the blade mounted on the saw. Remove and destroy blade if any cracks, chips, gouges, or loose or missing segments are present. Failure to do this can cause personal injury.
2. Inspect the drive wheel for gouges, warps, nicks, hairline cracks, wear, dirt, or sprung condition. Replace the drive wheel and blade immediately if any of these conditions are present. Any blade to be installed must comply with all the safety information and specifications listed in Chapter 2. Destroy any damaged blade as described in Section 4.2.
3. Inspect the hydraulic system hoses and fittings as described in Section 3.1.1. Failure to do this can cause personal injury. Never try to repair a damaged hose. Replace it immediately.
4. Wipe all tool surfaces clean of dirt and foreign material.

4.3 BLADE AND DRIVE WHEEL REMOVAL AND INSTALLATION

Drive Wheel and Blade are purchased together as item (36), **and must be replaced at the same time.**

- 4.3.1 **Blade and Drive Wheel Removal :** For item numbers in () after part descriptions below, refer to Part List on pg. 16 and enclosed Exploded Assembly Drawings, pgs. 19 - 22.
 1. Remove the (4) Roller Covers (39) with a phillip's head screwdriver by removing (2) screws ph #10 (31) per each cover.
 2. Loosen the blade adjusting (knurled) Knob (41).
 3. Loosen and remove the (2) 3/8"HHCS's (25,20,44) using a 9/16" wrench.

4. Disconnect the plastic Water Hose (38) @ the ¼" 90 deg. elbow (40), by pressing the end of a flat head screwdriver against the end of the black plastic elbow , force parallel with the tube , in the direction of the elbow. While doing this, pull the plastic tube out of the elbow.
5. Remove the Roller Frame (1) with the blade (36) from the Gearbox Housing(16)
6. Remove the Blade Guide (18A), or (2) spacers(18B),(when optional blade guide is not purchased), by removing (2) ¼" HHCS's (29,21,3) from Roller Frame.
7. Loosen (4) Rollers: by loosening each ¼" HHCS(6,4,5), then turning ea. Ecc. shaft (7) slot to 3 o'clock/9 o'clock position from the blade, with a flat head screw driver.
8. Blade will now be free to slide out of Roller Frame slot opening.
9. Ref.: Drive Wheel Removal and Installation Diagram, Figure 4-1, pg. 12:
Remove the Drive Wheel (36) from the Gearbox Housing (16) by loosening the (2) #10 SHCS's (23), with a 5/32" (.156") hex. wrench. In order to keep the Drive Wheel from turning while loosening the (2) screws, hold the Drive Wheel Mounting Flange (15) around the outside edge with a vice grip pliers.

4.3.2 Blade and Drive Wheel Installation (continued from above step).

1. Slide the Mounting Flange (15) onto the New Drive Wheel (36) and slide both onto the drive shaft of the Gearbox Housing (16).
2. Insert the (2) lock washers (24) and (2) #10 SCHS's (23) and tighten with a 5/32" (.156") hex. wrench. In order to keep the Drive Wheel from turning while tightening the (2) screws, hold the Drive Wheel Mounting Flange (15) around the outside edge with a vice grip pliers
3. Insert the New Blade (36) into the Roller Frame (16) slot opening, with the blade side grooves positioned within the (2) Guide Rollers item(2). Located on the far side while facing from the motor side.
4. Adjust the (4) Eccentric Shafts (7), so that the Blade is centered within the blade slot opening of the Roller Frame (1), making sure the side grooves of the Blade are engaged within the Guide Rollers(2).
5. Tighten the (4) Eccentric Shafts (7), so that the (4) Rollers exert enough force on the blade, such that when the blade is turned by hand, the rollers rotate. Also, while turning the blade by hand, when you put your thumb on each roller, you can stop the rotation of that roller. This assures that the contact between the blade and the rollers is neither too loose or too tight.
6. Tighten the (4) ¼" HHCS's (6), one on each Roller. This locks the Rollers into position.
7. Position the Roller Frame (1), with the blade in position, onto the Gearbox Housing (16), so that the "V" groove on the inside diameter of the Blade engages with the Drive Wheel (36) on the Gearbox Housing.
8. Adjust the Knurled Knob Adjusting Screw (41) so that the Blade "V" seats tightly against the Drive Wheel "V". This contact provides the frictional force necessary for the Drive Wheel to rotate the blade.
9. Tighten the (2) 3/8" HHCS's (25, 20, 44) that attach the Roller Frame to the Gearbox Housing. This locks the position of the Drive Wheel to the Blade.
10. Insert the Blade Guide (18A), or the (2) spacers (18B), into position of the Roller Frame (1) with (2) HHCS's (29,21,3).
11. Insert the plastic Hose (38) into the ¼" 90 Elbow (40).
12. Run the RingSaw (without water), and observe the Blade rotation and (4) Roller's rotation:

- The blade should not appear loose, vibrate, or wobble. It should rotate smoothly.
- Each Roller should not appear loose while turning with the blade rotation.
- An indication that the blade is too tight against the Drive Wheel will be premature wear at the contact points between these parts.
- The indication that the blade is too tight against the rollers is that you cannot stop the rotation of each roller by hand while turning the blade **with the other hand**. This condition will also cause premature wearing of the blade grooves and Guide Rollers (2) Fig.6-3. Pg. 18.

13. Install the (4) Roller Covers (39,31).

4.4 DRIVE WHEEL REMOVAL AND INSTALLATION DIAGRAM:

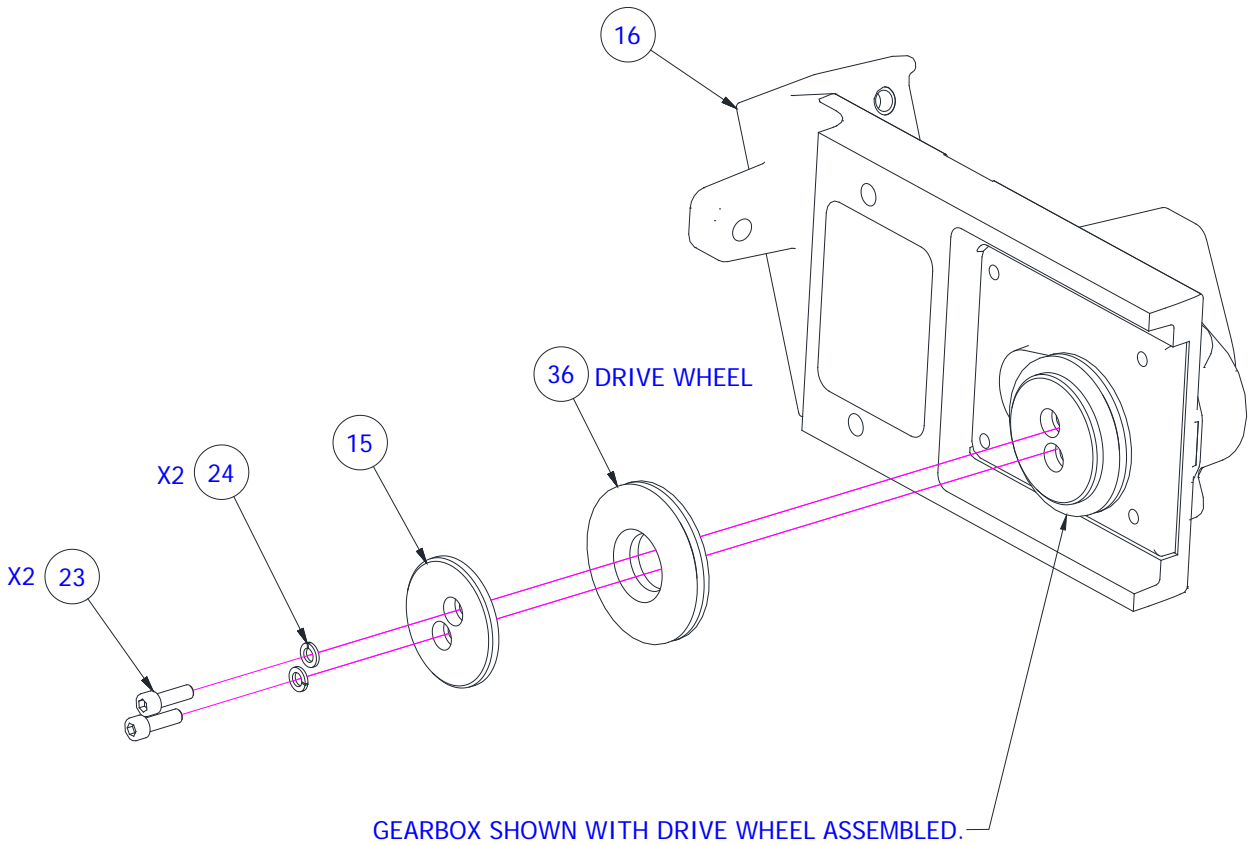

Figure 4-1
Drive Wheel Removal and Installation

5 TROUBLESHOOTING

5.1 LOCATING THE PROBLEM AREA

If the saw does not operate, the problem is either in the saw, the hoses, or the power supply. Locate the problem area as follows:

1. Stop the power supply.
2. Disconnect the existing saw from the hoses and power supply.
3. Connect a known working saw to the hoses and power supply. Refer to this manual for the proper hook-up procedure.
 - a. If the known working saw operates, the problem is in the disconnected saw. See the troubleshooting chart in Section 5.2.
 - b. If the known working saw does not operate, the problem is probably in the hose or power supply. Proceed to Step 4.
4. Stop the power supply.
5. Disconnect the existing hoses from the known working saw and power supply.
6. Connect a different set of hoses to the known working saw and power supply.
 - a. If the known working saw operates with the different set of hoses, the problem is in the disconnected hoses.
 - b. If the known working saw does not operate, the problem is in the power supply. See the power supply operating manual for troubleshooting.

5.2 TROUBLESHOOTING THE SAW

The following chart is intended to assist with troubleshooting the RS17RingSaw. While not all inclusive, the chart outlines the most common causes of a problem and the recommended course of action.

The troubleshooting guide for the associated power supply is in the instruction manual specifically for this unit.

SYMPTOM	CAUSE	CORRECTIVE ACTION
Saw inoperative	Saw connected to improper power supply hydraulic system.	See Chapter 2 for type of hydraulic system required. Verify power supply hydraulic system.
	No hydraulic fluid in system or fluid level low.	Check fluid level. Fill to full mark. Check system for leaks.
	Saw parts loose.	Tighten component hardware.
	Dirt or contaminants in saw parts.	Disassemble saw and clean parts.
	Saw parts worn or damaged.	Disassemble saw and replace worn or damaged parts.

Saw operates erratically	<p>Leak in system.</p> <p>Saw parts sticking or binding.</p> <p>Dirt or contaminants in saw parts.</p>	<p>Tighten fittings. Inspect all hoses for leaks as described in Section 3.1.1. REPLACE A LEAKING HOSE IMMEDIATELY. NEVER TRY TO REPAIR IT.</p> <p>Check for dirt or gummy deposits. Clean parts.</p> <p>Check for worn or damaged parts and replace as required.</p> <p>Be sure drive wheel & mounting flange are clean and straight so blade will run true on sides. See Chapter 4 for proper blade mounting procedure.</p> <p>Disassemble saw and clean parts.</p>
Saw operates slowly.	<p>Insufficient flow.</p> <p>Hydraulic fluid level low.</p> <p>Hydraulic fluid viscosity too heavy.</p> <p>Saw parts loose.</p> <p>Dirt or contaminants in saw parts.</p> <p>Saw parts worn or damaged.</p> <p>Excessive flow.</p>	<p>Refer to power source operator's manual for proper adjustment of flow.</p> <p>Check fluid level. Fill to full mark. Check system for leaks.</p> <p>Use fluid viscosity recommended. See Section 2.5.</p> <p>Tighten component hardware.</p> <p>Disassemble saw and clean parts.</p> <p>Disassemble saw and replace worn or damaged parts.</p> <p>Flow limiter functions as a safety trip reducing the flow to 5 GPM if there is excessive flow. Reduce flow to within recommended range.</p>
Saw feels hot.	<p>Power source heat exchanger malfunctioning</p> <p>Hydraulic fluid level low.</p> <p>Hydraulic fluid dirty.</p> <p>Engine speed excessive</p> <p>Excessive flow</p>	<p>Refer to power source operator's manual.</p> <p>Check fluid level. Fill to full mark. Check system for leaks.</p> <p>Drain reservoir, flush and fill with clean fluid. Change filter.</p> <p>Refer to power source manual for recommended engine speed.</p> <p>Refer to power source operator's manual for proper adjustment of flow.</p>
Saw leaks hydraulic fluid.	<p>Saw parts loose.</p> <p>Saw parts worn or damaged.</p>	<p>Tighten component hardware.</p> <p>Disassemble saw and replace worn or damaged parts.</p>
Saw control valve sticks or works hard.	<p>Check for dirt or gummy deposits.</p> <p>Misalignment or binding of control linkage.</p>	<p>Clean parts.</p> <p>Correct alignment, lubricate linkage joints, and replace damaged parts.</p>

	Valve parts worn or damaged.	Disassemble valve and replace worn or damaged parts.
Saw operates, but blade does not cut.	<p>Blade loose, spinning on drive wheel.</p> <p>Blade installed opposite to manufacturer's cutting rotation.</p> <p>Blade teeth dull.</p> <p>Wrong blade used for material being cut.</p>	<p>Ensure (2) #10 socket head cap screws are tightened securely as described in Chapter 4.</p> <p>Check for correct cutting rotation of blade. If installed incorrectly, remove and install correctly.</p> <p>Remove blade and sharpen, or install a sharp, new blade & drive wheel.</p> <p>Install blade recommended by manufacturer for material to be cut.</p>



WARNING:

ANY BLADE FROM YOUR SUPPLIER MUST MEET THE DESIGN CRITERIA LISTED IN CHAPTER 2. USING BLADES ON THIS SAW THAT DON'T MEET THESE REQUIREMENTS CAN CAUSE EQUIPMENT DAMAGE AND/OR PERSONAL INJURY.

6 PARTS LIST

The following parts list applies to the RS17 RingSaw only. The parts list for the hydraulic power source is in the separate manual supplied for this item. Each item number on the following parts list can be matched with the item number shown on the Figure 6-1 assembly drawing.

ITEM	PART NUMBER	DESCRIPTION	QTY	BASE UNIT
1	2017206	ROLLER FRAME ASSY BLACK	1	EA
2	5817920	SPRING,TORQ 3/4OD X .062MW X 90D	1	EA
3	5806393	WASHER FLAT SAE 1/4 CZP	2	EA
4	5806366	NUT HEX TOPLOCK 1/4-20 CZP	3	EA
5	5894074	SCREW SET SOC 1/4-20 X 1/4 SS	4	EA
6	2017940	RINGSAW TOP GUARD BLACK	1	EA
7	7617935	WHEEL 2" X 13/16 X 5/16 BORE POLYPROPYLENE	1	EA
8	2017407	RS17 RINGSAW GUARD SPRING SHAFT	2	EA
9	5817923	SPRING TORQ 3/4OD X .062MW X 180D CZP	1	EA
10	2017404	RS17 RINGSAW FRONT HANDLE MTG BAR	1	EA
11	2017200	RS17 RINGSAW FRONT HANDLE/GRIP ASSY	1	EA
12	5050418	RNGSAW/C100 HNDL/VLV SUB ASS BLU 12	1	EA
13	6517932	MOTOR HYD 12GPM RS17 RINGSAW P, H-PRESS SEAL	1	EA
14	5604684	ADAPTER 90D 3/4 SAE X JICM	4	EA
15	2017907	RS17 RINGSAW DRIVE WHEEL MTG FLANGE	1	EA
16	2017203	RS17 RINGSAW GEARBOX ASSY BLUE	1	EA
17	5806317	SHCS 1/4-20 X 3/4	4	EA
18A	2017901	RS17 RINGSAW BLADE GUIDE WLDMT	1	EA
18B	2017904	RS17 RINGSAW BLADE SPACER	4	EA
19	5806247	HHCS 3/8-16 X 1 CZP	2	EA
20	5806407	WASHER FLAT EXT TOOTH 3/8 CZP	4	EA
21	5806394	WASHER FLAT EXT TOOTH 1/4" CZP	4	EA
22	5806241	SCREW PH MS 1/4-20X1/2 PHIL SS	2	EA
23	5891796	SHCS #10-24 X 5/8 SS	2	EA
24	5891799	LOCK WASHER HI COLLAR #10 SS	2	EA
25	5806249	HHCS 3/8-16 X 1-1/2 CZP	2	EA
28	5650911	ADAPTER 1/4 SLIP-ON TUBE X 1/4NPTM	1	EA
29	5806209	HHCS 1/4-20 x 1-1/2 CZP	5	EA
31	5894101	SCREW PH MS 10-24X1/2 PHIL SS	8	EA
32	6411952	MINISAW SPLASHGUARD 8X8X3/16	1	EA
33	5894136	SCREW PH MS 10-24 X 3/4"LG PHIL SS	2	EA
36	5217914	RING SAW BLADE 17" DIA X .165 W/ DRV. WHEEL	1	EA
37	5806206	HHCS 1/4-20 X 3/4 CZP	2	EA
38	5920843	HOSE POLYETHYLENE 1/4 OD	.5	FT
39	2017212	RS17 RINGSAW ROLLER COVER BLACK	4	EA
40	5617917	ADAPTER 90D 1/4TUBE PUSHLOK X 1/4NPTM	1	EA
41	5891790	KNOB MALE 3/8-16 X 1-3/4 STUD(1-1/2 OD)SS	1	EA
42	6017926	RS17 RINGSAW PRESSURE TUBE 12GPM W/FTGS	1	EA
43	6017929	RS17 RINGSAW RETURN TUBE 12GPM W/FTGS	1	EA
44	5806406	WASHER FLAT SAE 3/8 CZP	4	EA
45	2017934	RS17 RINGSAW SPLASH GUARD HINGE	1	EA
46	5806377	NUT HEX 3/8-16 CZP	1	EA
47	6204036	TAG MODEL RGC HYDRTOOL	1	EA
48	6205650	DECAL ROTATION ARROW	1	
49	6219274	DECAL 12 GPM	1	EA
50	6205685	DECAL MADE IN USA	1	EA
51	6204405	DECAL RGC LOGO	1	EA
52	6239972	DECAL "PPE LOGO"	1	EA

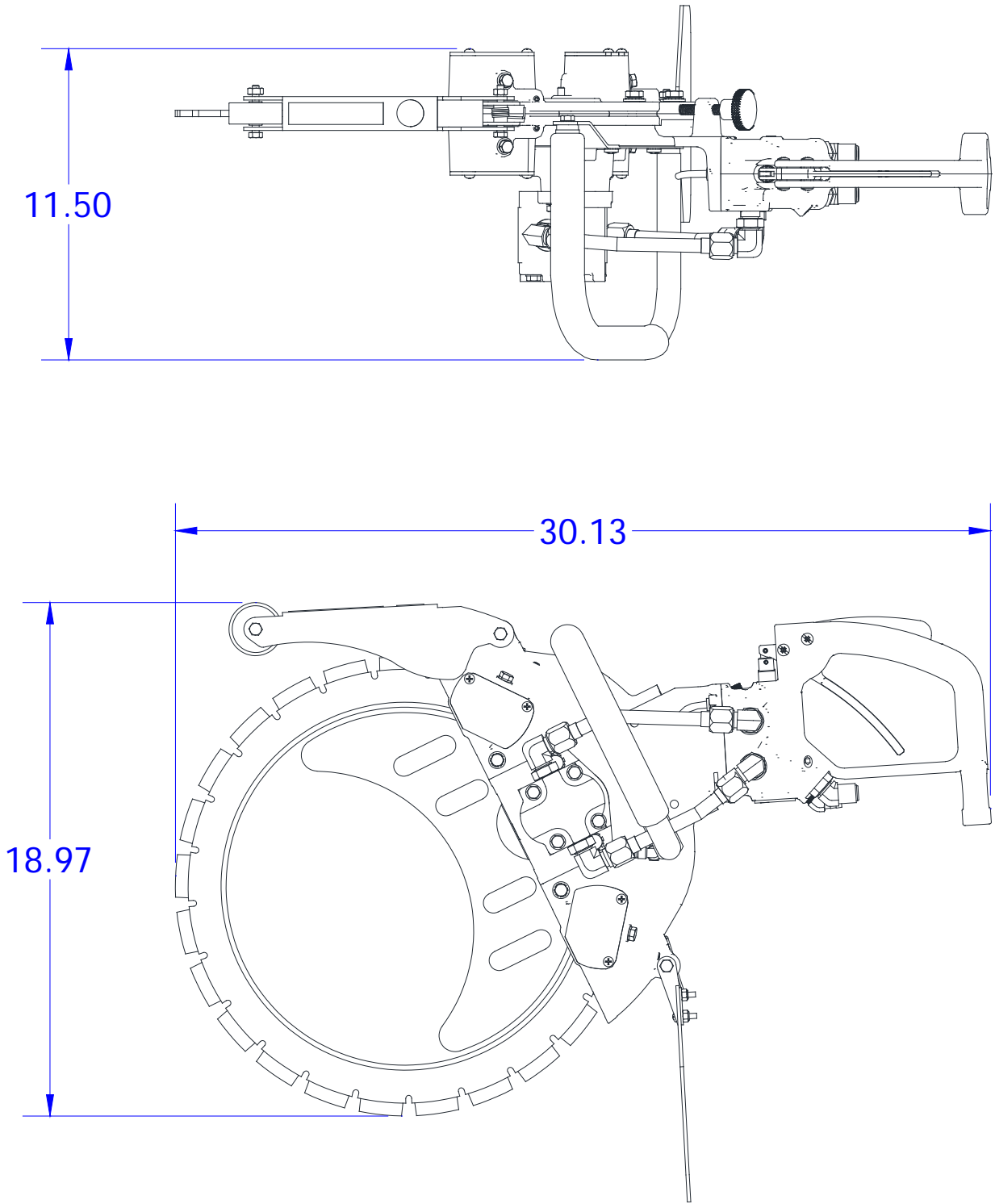

Figure 6-1

RS17 RINGSAW OVERALL DIMENSIONS

HOW DOES YOUR RGC RING SAW WORK?

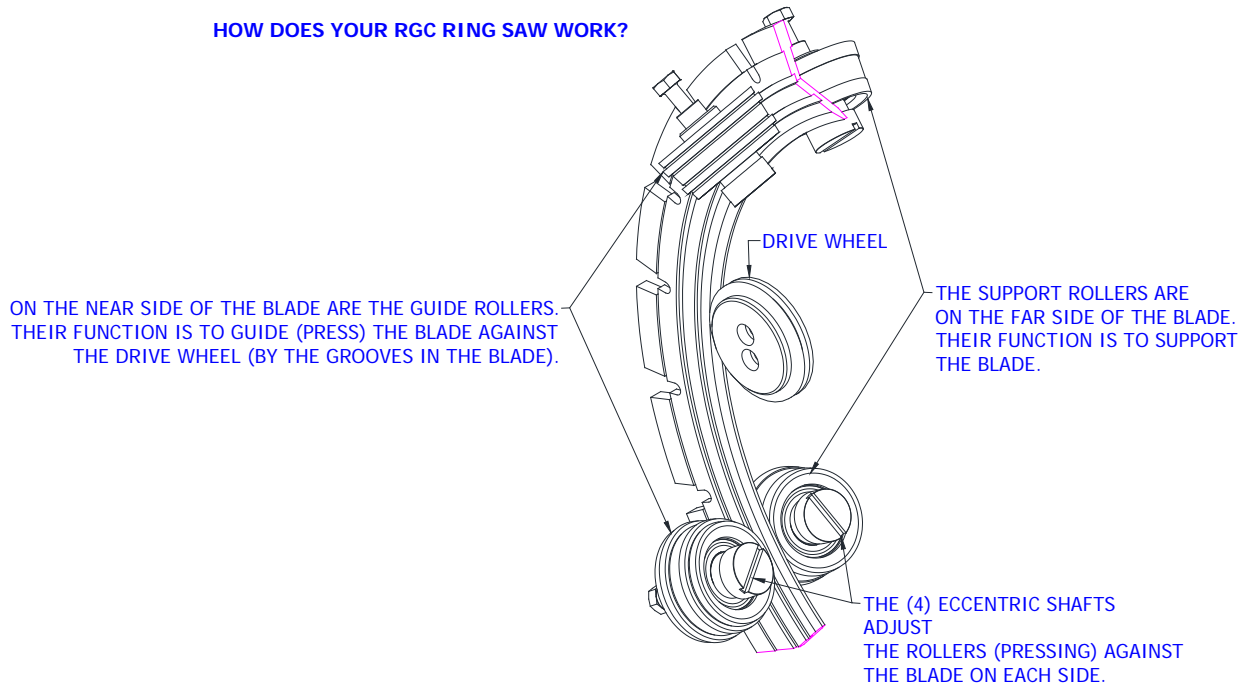

Figure 6-2

Roller Assemblies in Roller Frame Diagram:

ITEM	PART NUMBER	DESCRIPTION	QTY	BASE UNIT
1	2017218	RS17 RINGSAW FRAME BLACK	1	EA
2	2017219	RS17 GUIDE ROLLER	2	EA
3	2017937	RS17 SUPPORT ROLLER	2	EA
4	5806393	WASHER FLAT SAE 1/4 CZP	4	EA
5	5806398	WASHER SPLIT LOCK 1/4	4	EA
6	5806209	HHCS 1/4-20 UNC X 1-1/2 CZP	4	EA
7	2017925	RS17 ROLLER ECCENTRIC SHAFT	4	EA
8	5117902	BEARING, BOCA (15X35X15.9MM) SS	4	EA
9	2017931	RS17 ROLLER SHAFT SPACER	4	EA

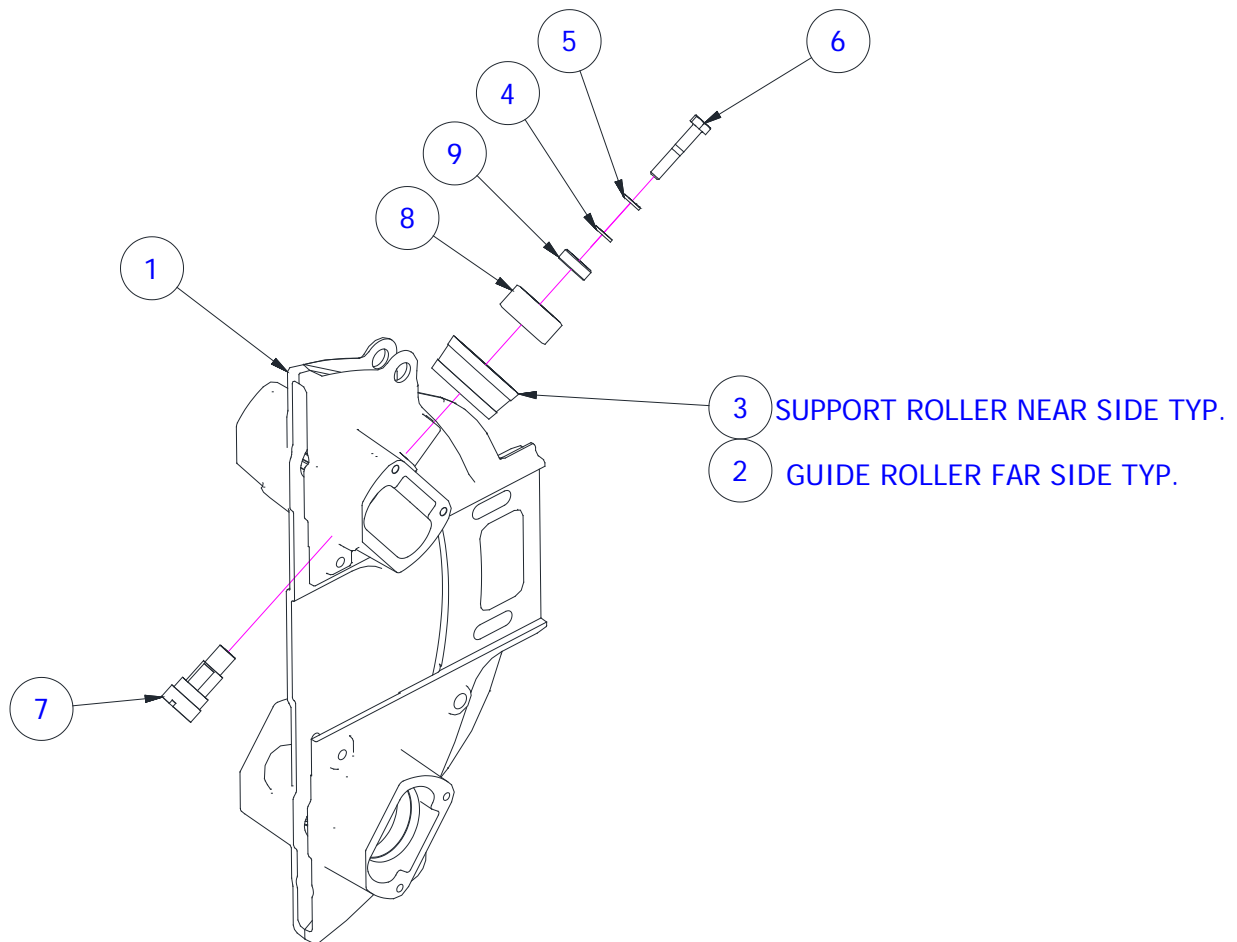

Figure 6-3

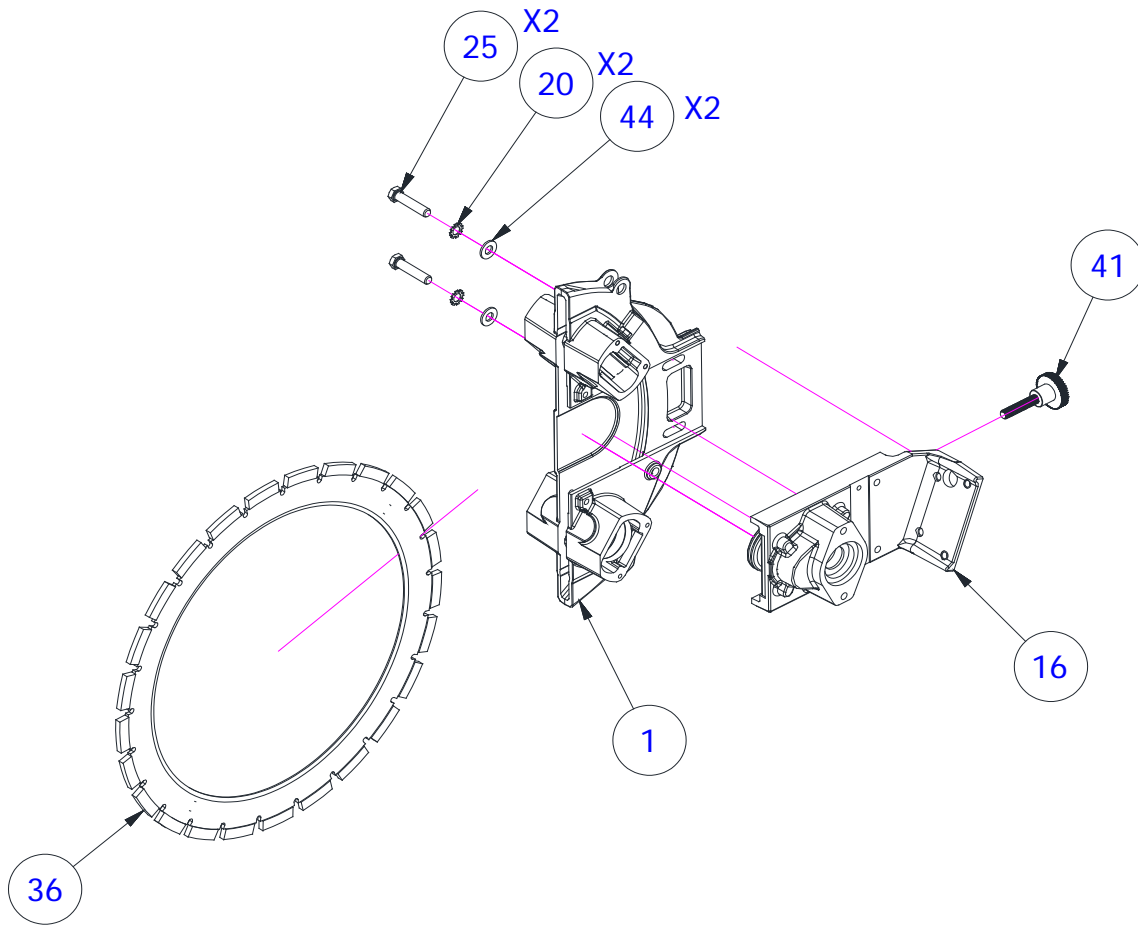

Figure 6-4
Exploded Assembly Part 1

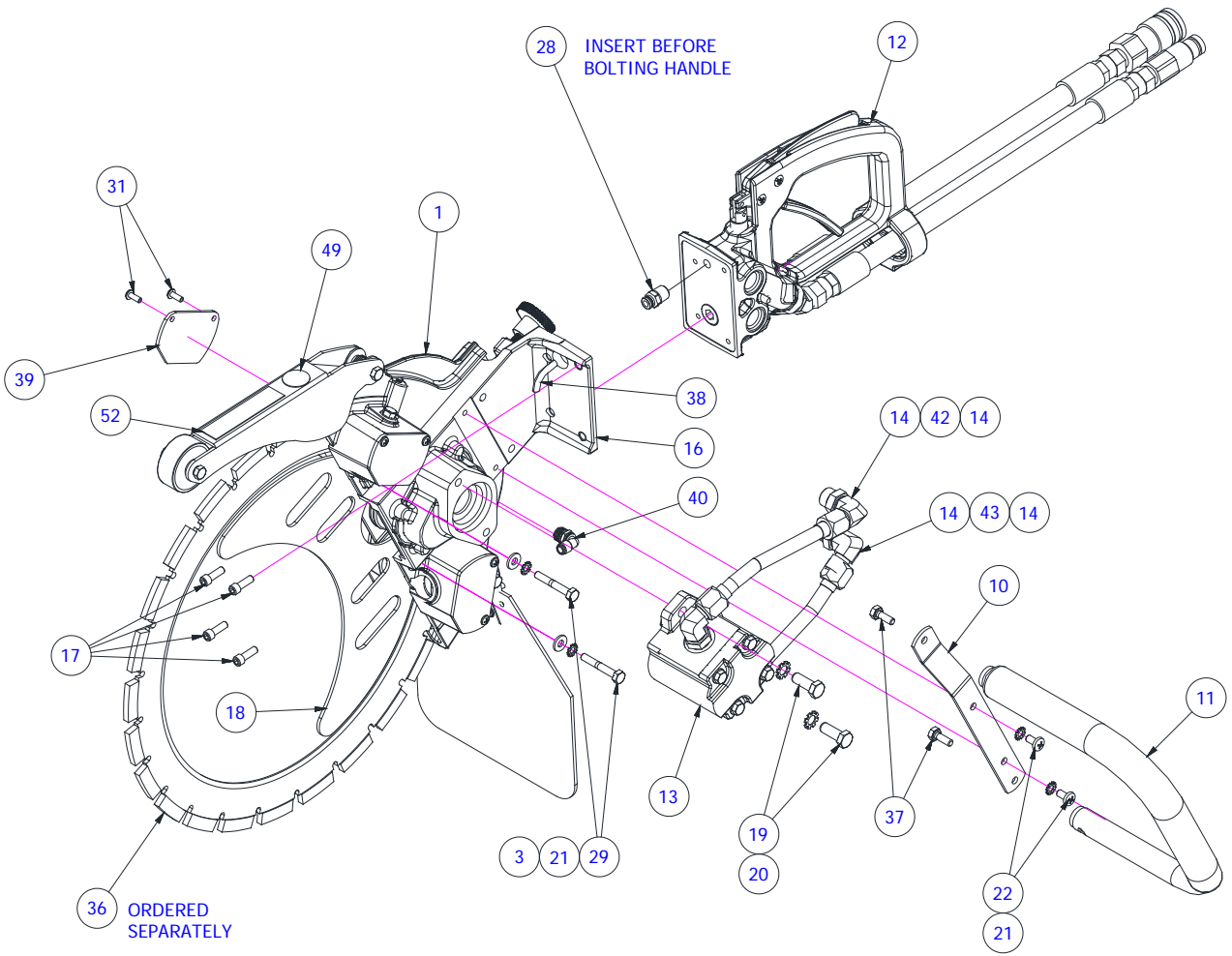

Figure 6-5
Exploded Assembly Part 2

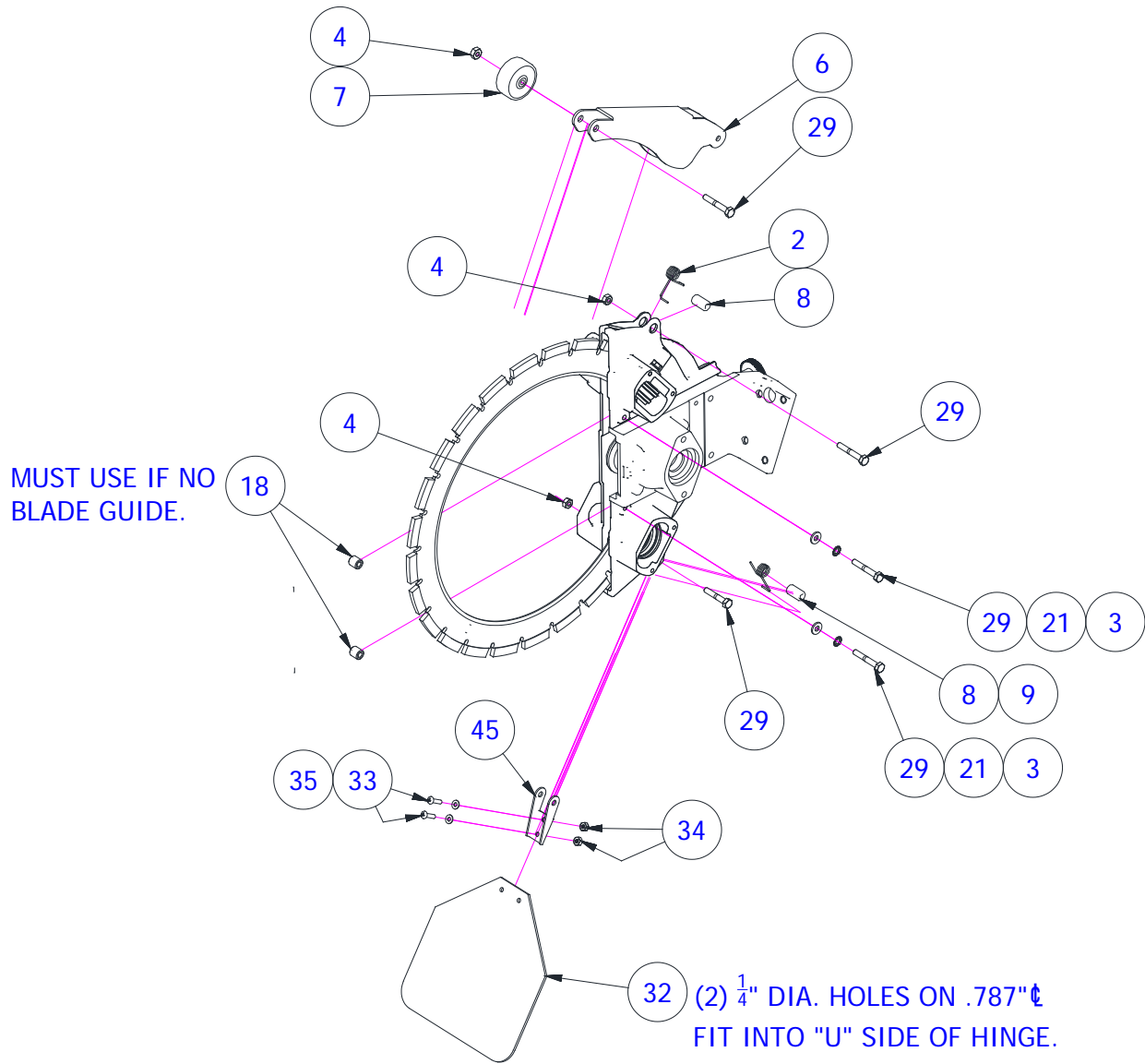

Figure 6-6
Exploded Assembly Part 3

LIMITED PRODUCT WARRANTY

**Reimann & Georger Corporation
Hoisting and Construction Products**

A. LIMITED WARRANTY

Reimann & Georger Corporation (the "Manufacturer") warrants to the original purchaser (the "Buyer") that all Reimann & Georger Hoisting and Construction products shall be free of defects in material and workmanship for a period of one (1) year from date of original purchase.

B. MANUFACTURER'S OBLIGATIONS

The Manufacturer's sole obligation under this Limited Warranty is the repair or, at the Manufacturer's discretion, the replacement of parts found to be defective. Parts and equipment must have authorization from the Manufacturer prior to return to the Manufacturer or repair by an authorized service person. Costs of transportation and other expenses connected with replacing or repairing parts are not covered under this Limited Warranty.

C. PARTS MANUFACTURED BY OTHERS

This Limited Warranty does not cover any parts manufactured by others. Such parts are subject to the warranty, if any, of their respective manufacturers, and are to be repaired only by a respective authorized service person for such parts. The Manufacturer shall have no obligation to undertake repairs of parts manufactured by others.

D. NO SPECIAL, INCIDENTAL, OR CONSEQUENTIAL DAMAGES

IN NO EVENT SHALL THE MANUFACTURER BE LIABLE TO THE BUYER OR ANY OTHER PERSON FOR ANY INDIRECT, SPECIAL, INCIDENTAL OR CONSEQUENTIAL LOSSES OR DAMAGES CONNECTED WITH THE USE OF THE PRODUCT UNDER THIS LIMITED WARRANTY. SUCH DAMAGES FOR WHICH THE MANUFACTURER SHALL NOT BE RESPONSIBLE INCLUDE, BUT ARE NOT LIMITED TO, LOST TIME AND CONVENIENCE, LOSS OF USE OF THE PRODUCT, THE COST OF A PRODUCT RENTAL, COSTS OF GASOLINE, TELEPHONE, TRAVEL, OR LODGING, THE LOSS OF PERSONAL OR COMMERCIAL PROPERTY, AND THE LOSS OF REVENUE.

E. NO LIABILITY IN EXCESS OF PURCHASE PRICE

IN NO EVENT SHALL THE MANUFACTURER'S OBLIGATIONS UNDER THIS LIMITED WARRANTY EXCEED THE PURCHASE PRICE OF THE PRODUCT.

F. NO EXTENSION OF STATUTE OF LIMITATIONS

ANY REPAIRS PERFORMED UNDER THIS WARRANTY SHALL NOT IN ANY WAY EXTEND THE STATUTES OF LIMITATIONS FOR CLAIMS UNDER THIS LIMITED WARRANTY.

G. WAIVER OF OTHER WARRANTIES

THE EXPRESS WARRANTIES SET FORTH IN THIS LIMITED WARRANTY ARE IN LIEU OF AND EXCLUDE ANY AND ALL OTHER WARRANTIES, EXPRESS OR IMPLIED, INCLUDING, BUT NOT LIMITED TO, THE IMPLIED WARRANTIES OR MERCHANTABILITY AND FITNESS FOR A PARTICULAR PURPOSE.

H. PROCEDURE FOR WARRANTY PERFORMANCE

If the product fails to perform to the Manufacturer's specifications, the Buyer must provide the Manufacturer with the applicable model and serial numbers, the date of purchase, and the nature of the problem.

I. ADDITIONAL EXCLUSIONS FROM THIS LIMITED WARRANTY. THIS LIMITED WARRANTY DOES NOT COVER ANY OF THE FOLLOWING:

1. Equipment which has been abused, damaged, used beyond rated capacity, or repaired by persons other than authorized service personnel.
2. Damage caused by acts of God which include, but are not limited to, hailstorms, windstorms, tornadoes, sandstorms, lightning, floods, and earthquakes.
3. Damage under conditions caused by fire or accident, by abuse or by negligence of the user or any other person other than the Manufacturer, by improper installation, by misuse, by incorrect operation, by "normal wear and tear", by improper adjustment or alteration, by alterations not completed by authorized service personnel, or by failure of product parts from such alterations.
4. Costs of repairing damage caused by poor or improper maintenance, costs of normally scheduled maintenance, or the cost of replacing any parts unless done as the result of an authorized repair covered by the one (1) year Limited Warranty.
5. Costs of modifying the product in any way once delivered to the Buyer, even if such modifications were added as a production change on other products made after the Buyer's product was built.

J. NO AUTHORITY TO ALTER THIS LIMITED WARRANTY

No agent, representative, or distributor of the Manufacturer has any authority to alter the terms of this Limited Warranty in any way.